

OWNER'S INSTRUCTION DIY TRAILER KIT

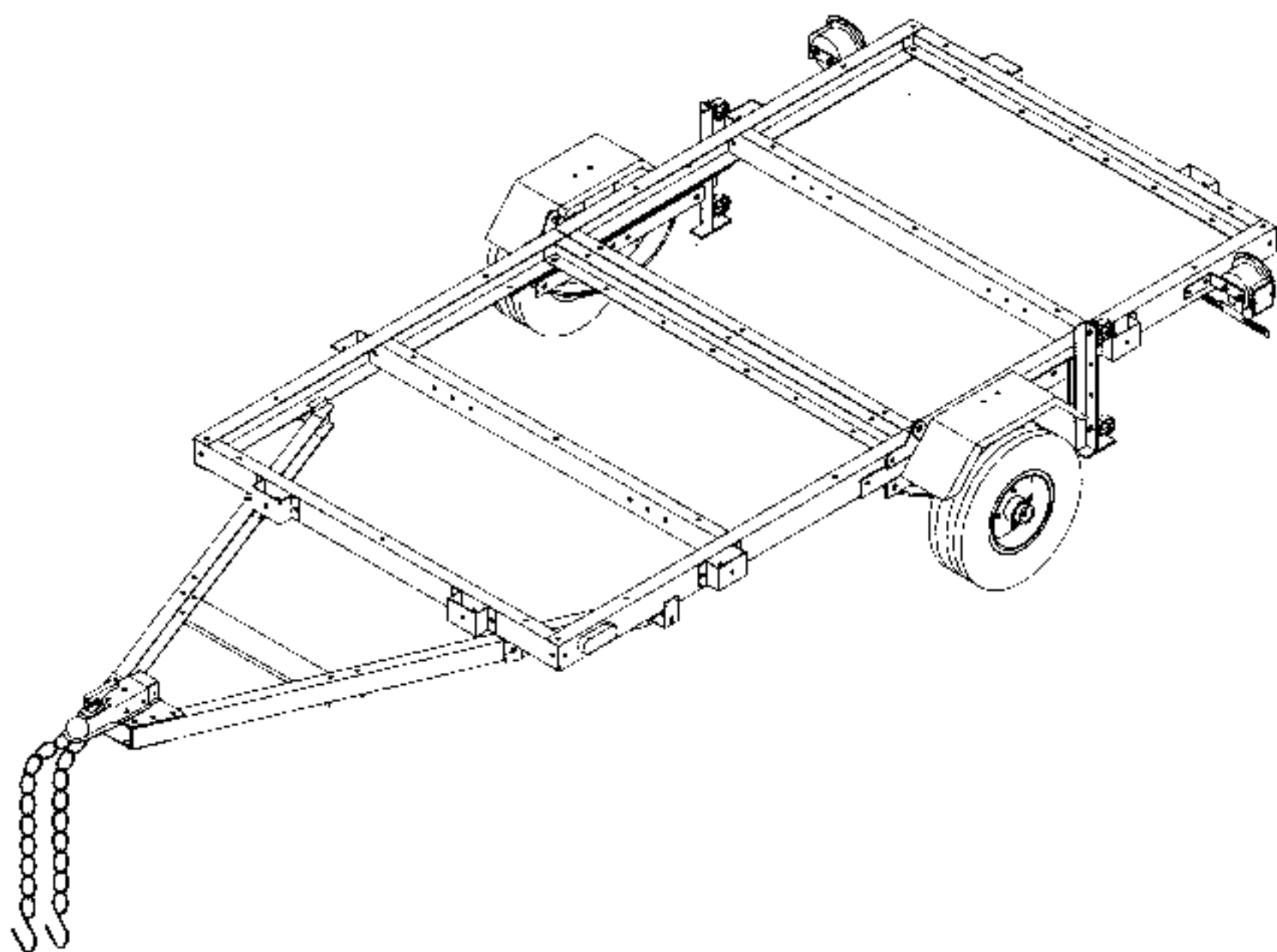

Item No.: LCI-850T
 LCI-850T A

LCI-850T TRAILER PARTS LIST

PARTS			NO.	Q'TY	DESCRIPTION
NO.	Q'TY	DESCRIPTION			
			26	2	Tail Light Bracket
1FL	1	Front Left Side Rail	27	1	License Plate Bracket
1FR	1	Front Right Side Rail	28L	1	Left Tail Light
1RL	1	Rear Left Side Rail	28R	1	Right Tail Light
1RR	1	Rear Right Side Rail	29	1	Safety Pin
2A	1	Front Cross Member	30L	1	Left Caster Base
2B	5	Cross Member	30R	1	Right Caster Base
3	2	Connecting Rail	31	2	Grease Fitting
4	1	Spare Tire Bar			
5	1	T Plate	HARDWARE		
6	1	Coupler Base	A	50	3/8" x 3/4" Bolt
7	1	Coupler	B	24	3/8" x 1" Bolt
8	1	Safety Chain	C	1	3/8" x 1-1/2" Bolt
9	2	L Latch	D	4	3/8" x 1" Carriage Bolt
10	2	Rotation Plate (Flat)	E	2	9/16" x 3" Bolt
11L	1	Left Rotation Plate	F	4	9/16" x 3-1/4" Bolt
11R	1	Right Rotation Plate	G	91	3/8" Nylon Nut
12L	1	Left Spring Hanger	H	5	3/8" Hex Nut
12R	1	Right Spring Hanger	I	6	9/16" Nylon Nut
13	4	Caster	J	8	Wheel Nut
14	2	Spring Plate	K	2	Castle Nut
15	2	Spring	L	18	3/8" Spring Washer
16	1	Axle	M	11	3/8" Flat Washer
17	4	U Bolt	N	2	3/4" Flat Washer
18	2	Hub	O	2	5/32" Cotter Pin
19	2	Tire/Wheel Assembly	Q	2	3mm R Pin
20	2	Bearing	R	4	4mm Self Tapping Screw
21	2	Dust Cap	S	1	2mm R Pin
22	2	Fender	U	1	1/4" self Tapping Screw
23	2	Fender Seat	V	1	3/8" x 2" Bolt
24	2	Side Running Light	W	2	3/8" x 3-1/2" Bolt
25	8	Stake Clamp	X	6	3/8" x 1-1/4" Bolt

Read the instruction carefully and follow them step-by-step for easy assembly. You'll find a complete parts list on the previous page. Average assembly time is approximately 6 hours. You'll need the following tools to assemble your Trailer Kit.

TOOLS NEEDED:

3/4" socket or lug wrench
9/16" open end wrench
Screwdriver

9/16" box end wrench
Plier
Channel lock pliers

NOTE:

1. In assembling trailer parts, they are identified by standing at rear of Trailer and looking toward tongue.
2. Do not fully tighten bolts & nuts until the Trailer frames are completely assembled.
3. Periodically check all bolts and nuts for tightness, tighten as necessary.

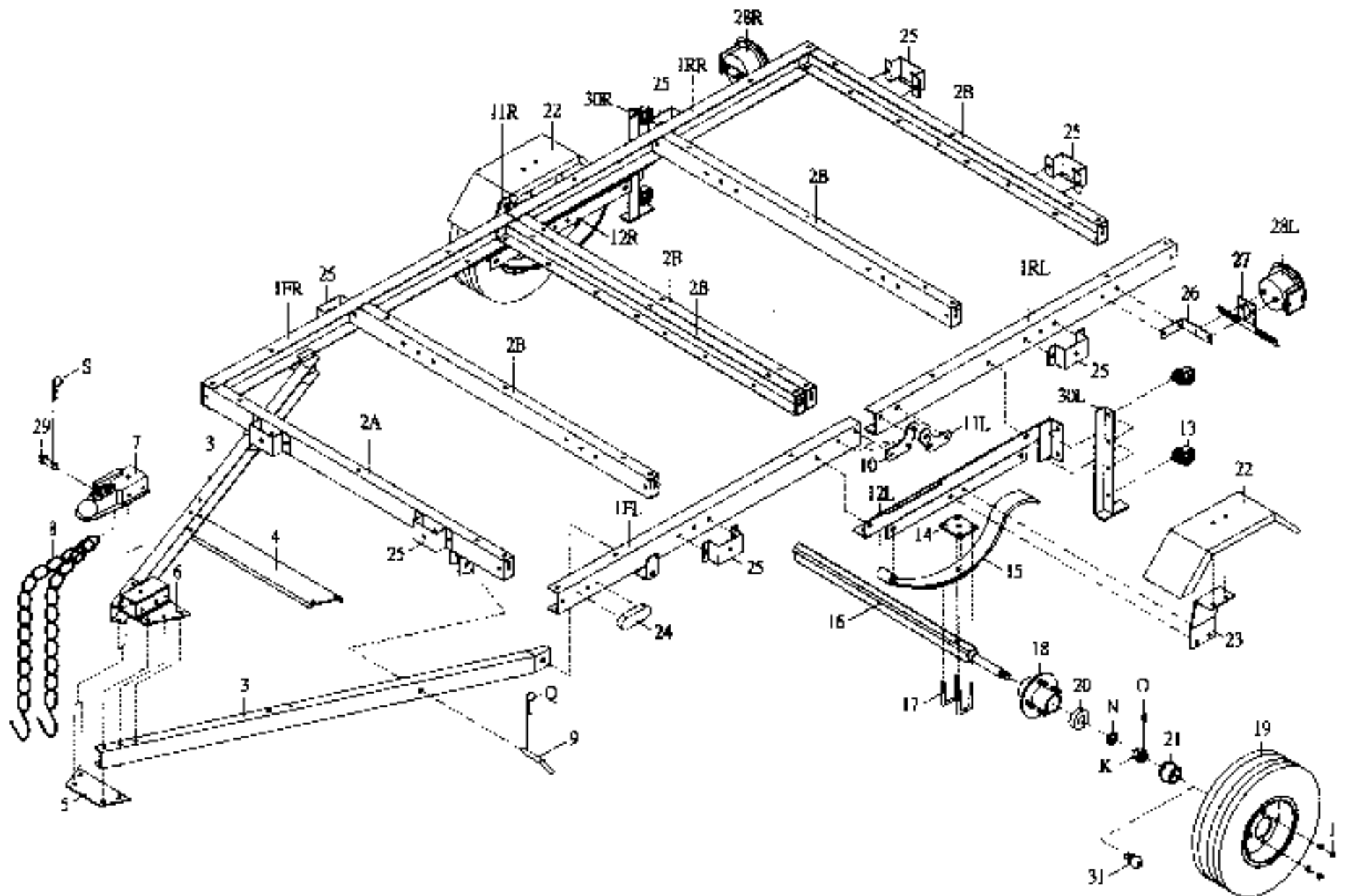

STEP 1

1. Lay out front left & right side rails (1FL, 1FR) and cross members (2A, 2B) as shown in diagram.
2. Assemble front left & right side rail (1FL, 1FR), front cross member (2A), cross members (2B), stake clamps (25) and flat rotation plates (10) by using $3/8"$ x $3/4"$ bolts and $3/8"$ nylon nuts (A, H), or $3/8"$ x $1"$ Bolts and $3/8"$ nylon nuts (B, H), as shown in diagram.

NOTICE :

1. The center cross member must fit in the rear holes of side rail (1FL, 1FR). Assemble center cross member, stake clamp and side rail by using $3/8"$ x $1"$ Bolts and $3/8"$ nylon nuts (B, H) as shown in diagram.
2. Do not tighten nuts until all bolts are positioned in place.

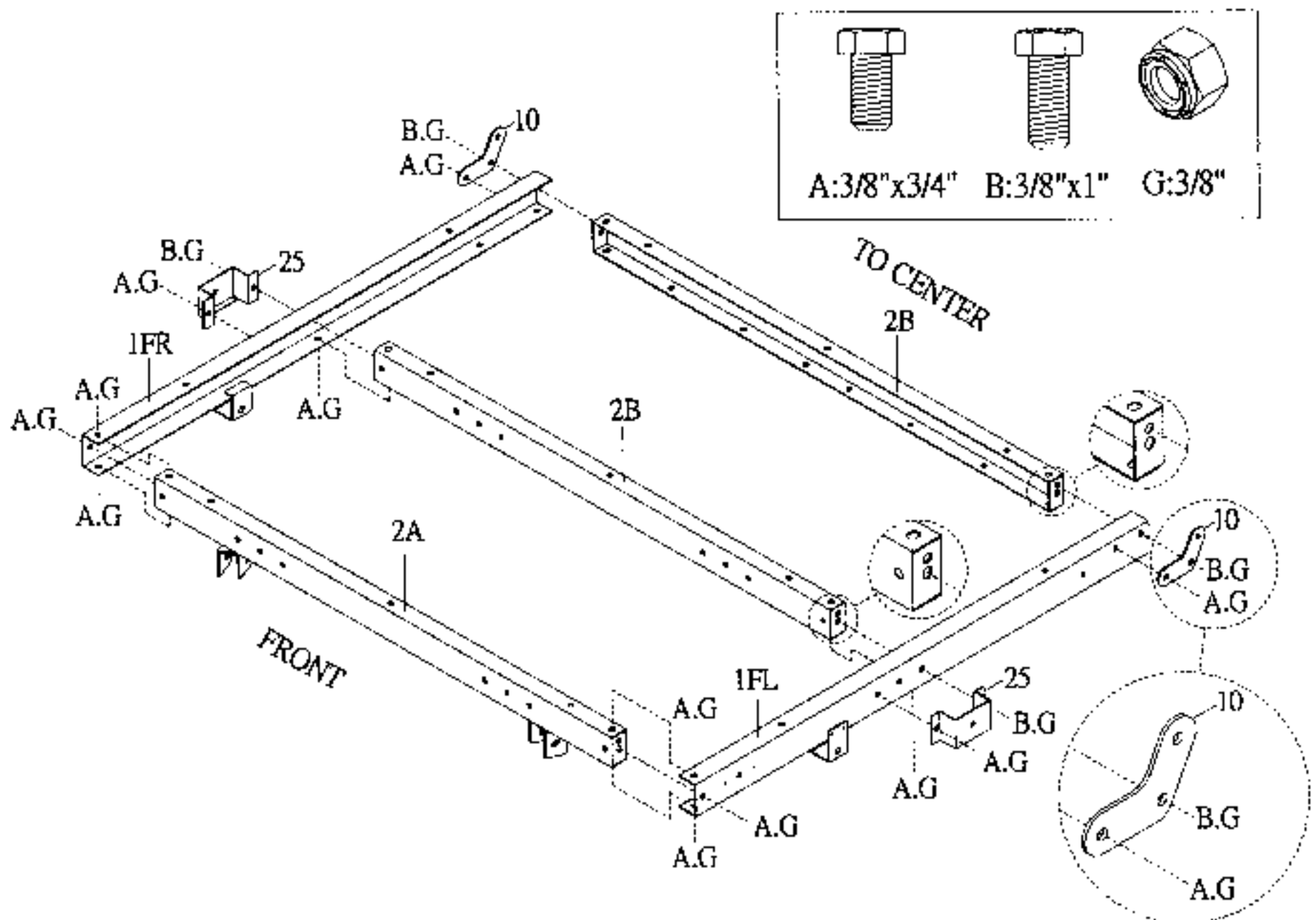

STEP 2

1. Attach connecting rails (3) to side rails (1FL, 1FR) by using $9/16"$ x $3"$ bolts (E) and $9/16"$ nylon nuts (I), then attach L latch (9) go through holes on front cross member (2A), put 3mm R pin (Q) into the hole of latch.
2. Attach coupler base (6) to connecting rails (3) by using $3/8"$ x $1-1/4"$ bolts (X), $3/8"$ flat washers (M), $3/8"$ spring washers (L) and $3/8"$ nylon nuts (G).
3. Attach T plate (5) to connecting rails (3) by using $3/8"$ x $1"$ bolts (B), $3/8"$ flat washers (M) and $3/8"$ nylon nuts (G).
4. Attach spare tire bar (4) to connecting rails (3) by using $3/8"$ x $3/4"$ bolts (A) and $3/8"$ nylon nuts (G).

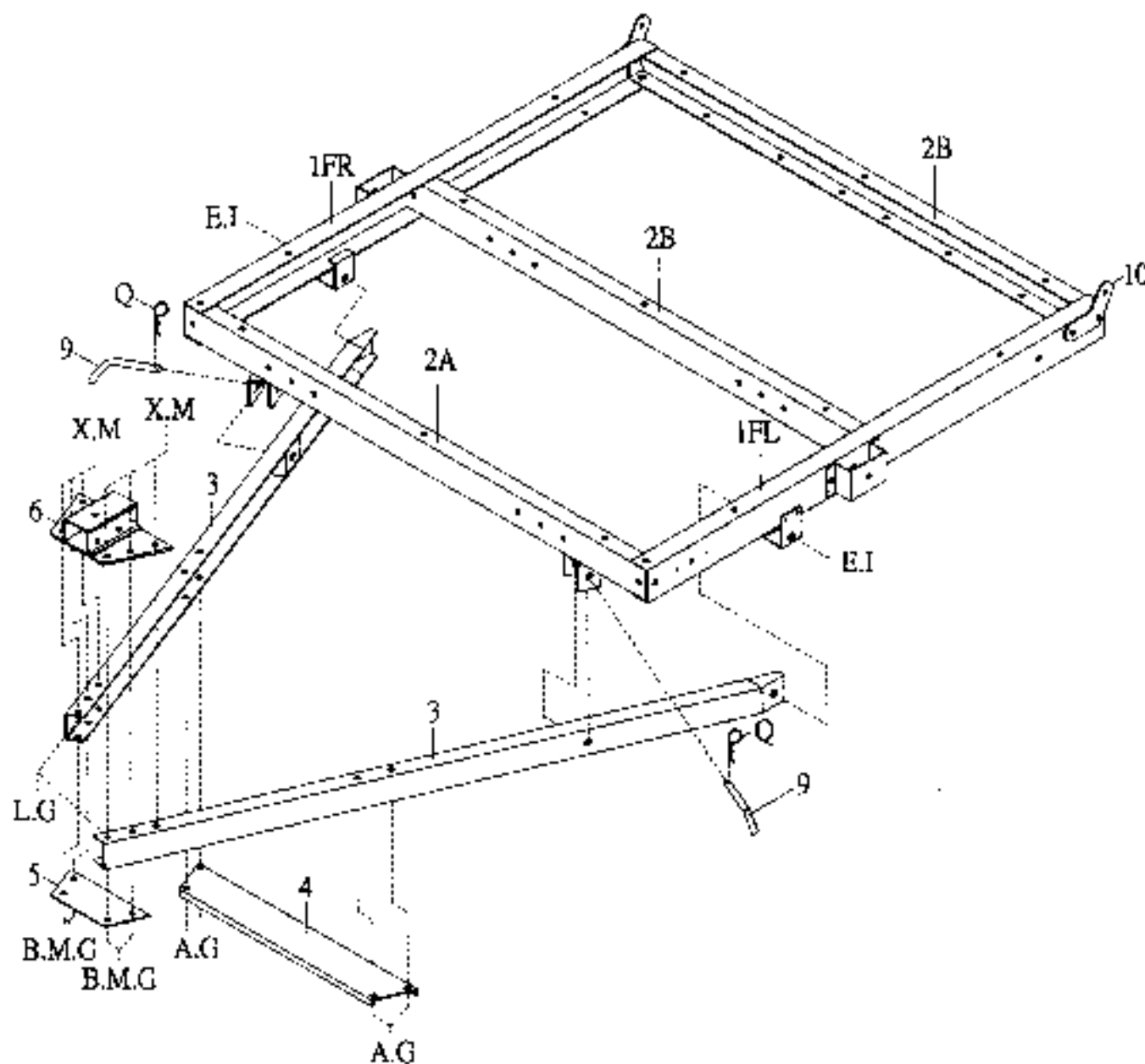
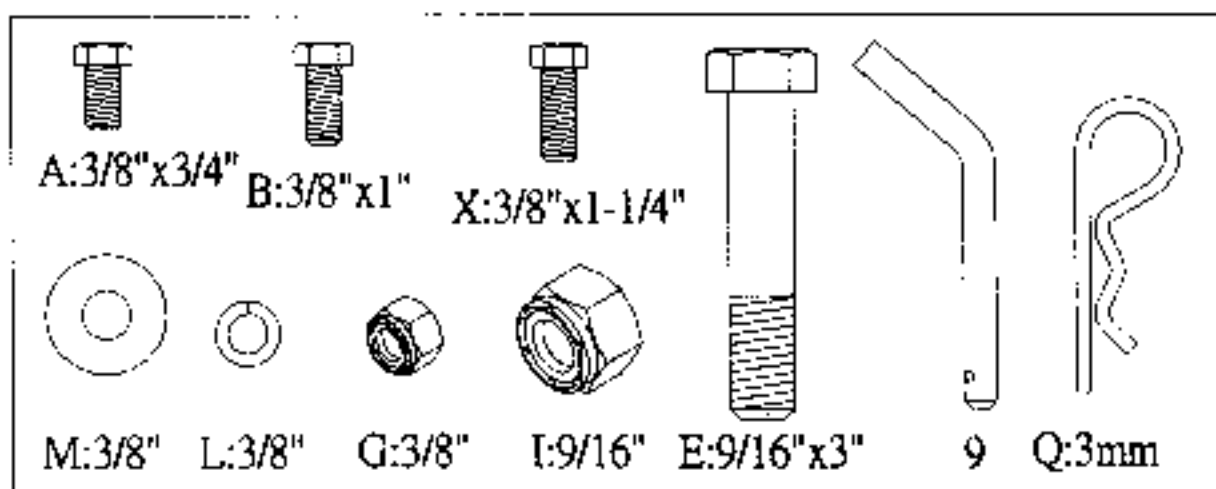

STEP 3

1. Lay out rear left & right side rails (1RL, 1RR) and cross members (2B) as shown.
2. Assemble rear left & right side rail (1RL, 1RR), cross members (2B), stake clamps (25) and left/right rotation plates (11L, 11R) by using 3/8" x 3/4" bolts and 3/8" nylon nuts (A, G) or 3/8" x 1" bolts and 3/8" nylon nuts (B, G) as shown in diagram.

NOTICE:

The center cross member must fit in the front holes of side rail (1FL, 1FR). Assemble center cross member, stake clamp and side rail by using 3/8" x 1" Bolts and 3/8" nylon nuts (B, H) as shown in diagram.

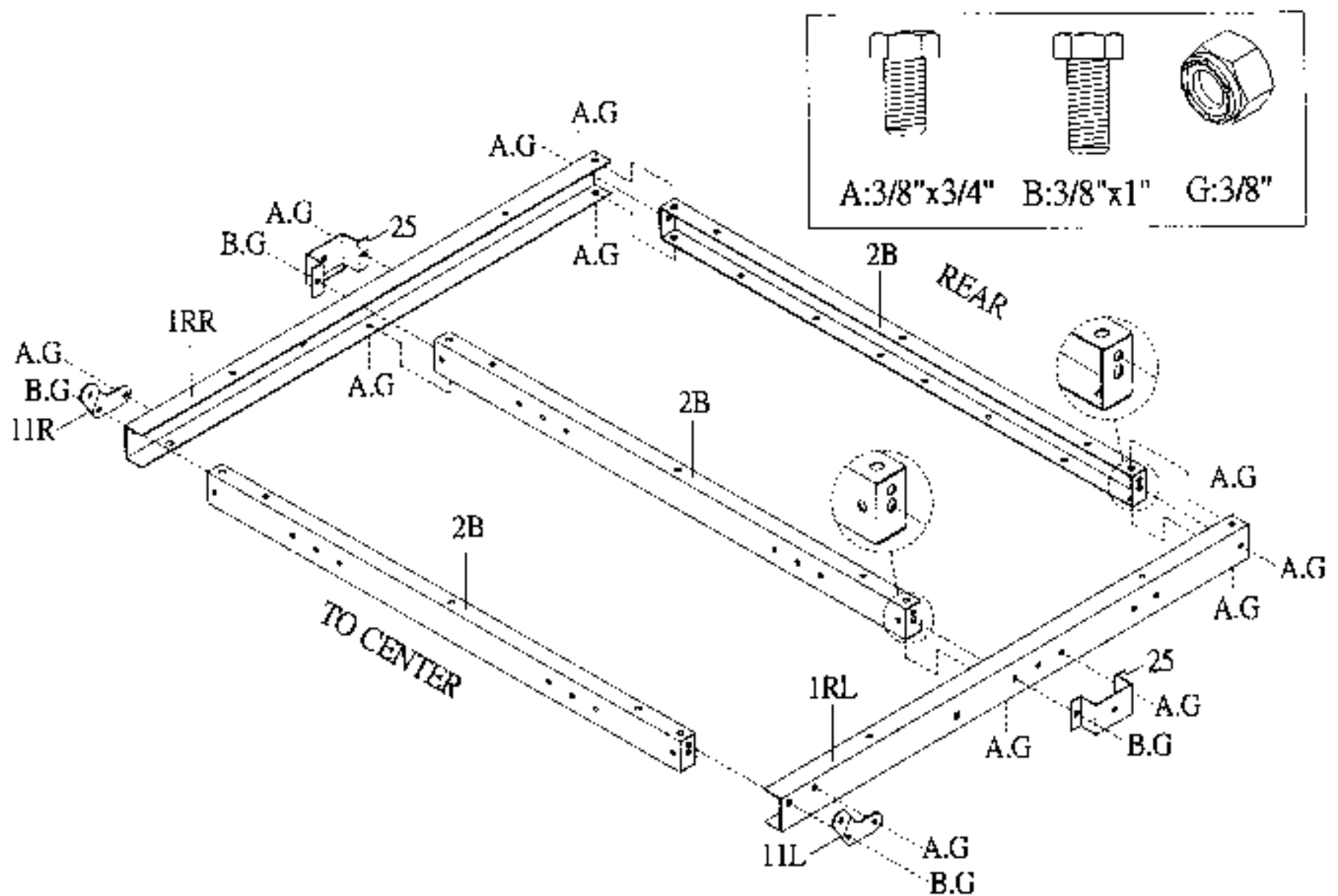

STEP 4

1. Assemble front portion (STEP 2) and rear portion (STEP 3) by using 3/8" x 3/4" bolts (A) and 3/8" nylon nuts (G) as shown in diagram. Do not over tighten nuts.
2. Fold trailer up as shown in diagram.

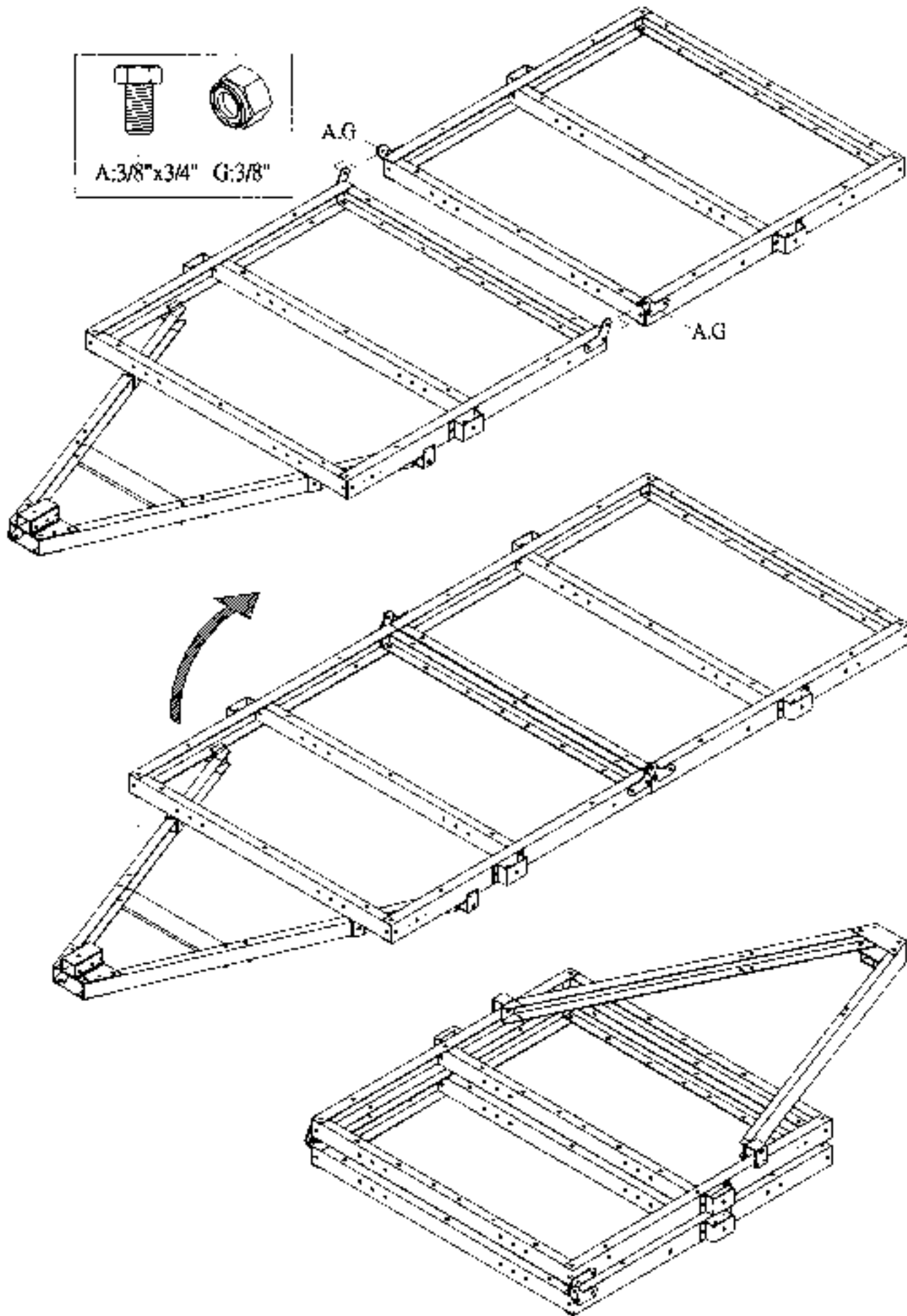

STEP 5

1. Assemble left/right spring hanger (12L, 12R) to front side rail (1FL, 1FR) by using $3/8"$ x 1" bolts and $3/8"$ nylon nuts (B, G) as shown in diagram.
2. Tight left/right caster base (30L, 30R) to left/right spring hanger by using $3/8"$ x 1" bolts and $3/8"$ nylon nuts (B, G).
3. Fix casters (13) to caster base by using caster's washers and nuts.

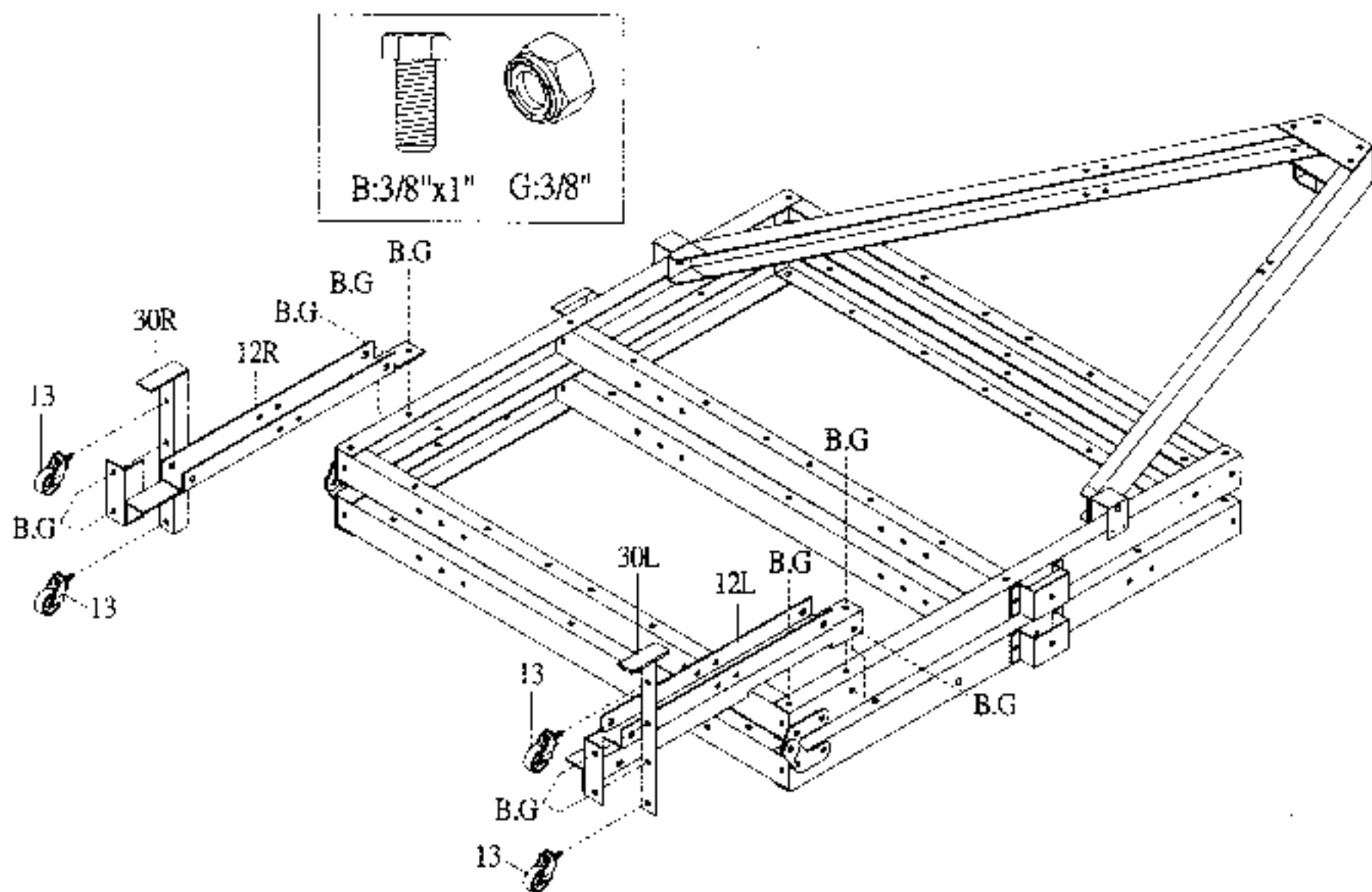

STEP 6

1. Assemble fender seats (23) to left/right spring hangers (12L, 12R) by using $3/8"$ x $3/4"$ bolts and $3/8"$ nylon nuts (A, G), then fix fenders (22) to fender seats (23) by using $3/8"$ x $3/4"$ bolts and $3/8"$ nylon nuts (A, G).
2. Attach slipper springs (15) to left/right spring hangers (12L, 12R) by using $9/16"$ x $3-1/4"$ bolts (F) and $9/16"$ nylon nuts (I), as shown in diagram.
3. Place axle (16) on top of slipper springs (15), the bolt head of slipper spring insert to both hole on axle. Place spring plates (14) under slipper spring, using U bolts (17) pass through axle (16), slipper springs (15) and spring plates (14), then lock it with $3/8"$ spring washers (L) and $3/8"$ nylon nuts (G).

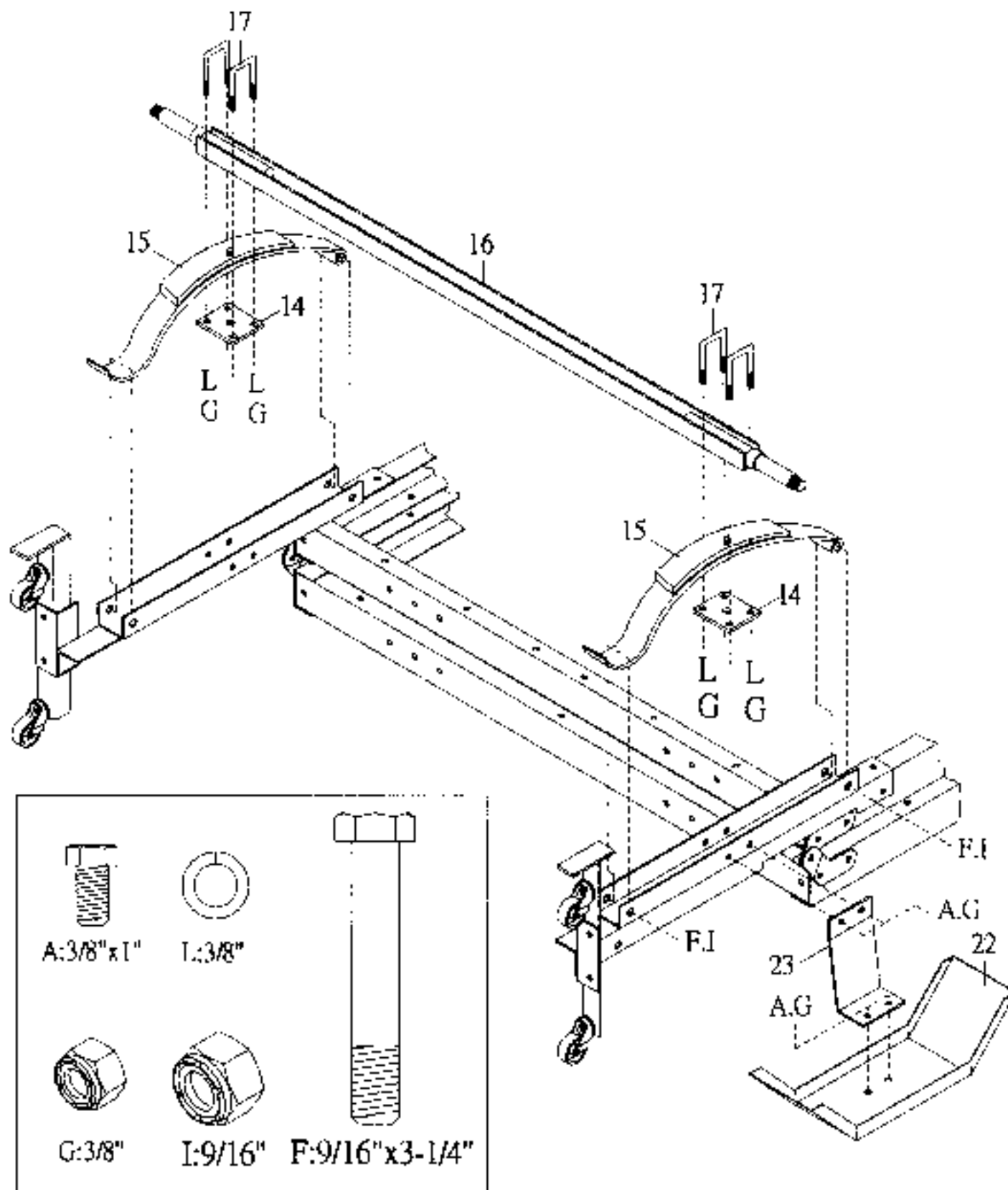

STEP 7

1. Carefully slide hubs (18) over spindles at each end of axle and push on outer bearings (20), 3/4" flat washers (N) and castle nuts (K), tighten them snugly.
2. NOTICE: BACK OFF SLIGHTLY A LITTLE BIT SO THAT WHEEL CAN JUST SPIN FREELY.
3. Push 5/32" cotter pin (O) through the hole in end of the spindles then spread cotter pin, then press dust cap (21) onto the hub. Fix grease fitting (31) on dust cap (21).
4. Put tire/wheel assembly (19) on hub set (18), then lock with wheel nuts (J) tighten with socket or lug wrench to 90FT-LBS (very tight), as shown in diagram.

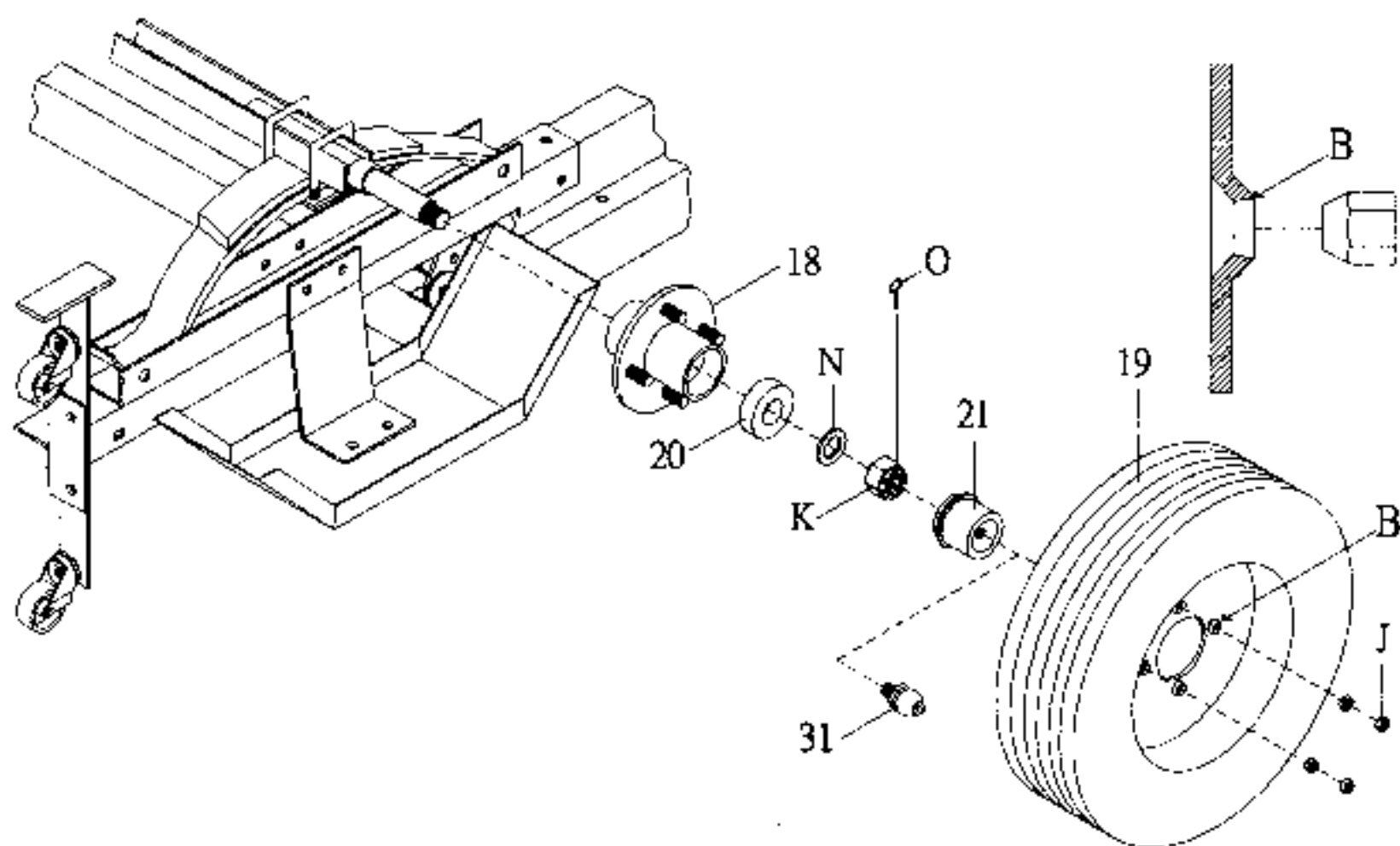

STEP 8

1. Extend trailer bed to full length by lifting upper section 180° towards rear of trailer.
2. Bolt coupler (7) to coupler base (6) by using 3/8" x 3-1/2" bolts (W) and 3/8" nylon nuts (G).
3. Attach safety chain (8) to coupler by using 3/8" x 1-1/2" bolt (C) go through the center link of the chain, lock with 3/8" flat washer (M) and 3/8" nylon nut (G).
4. Lock coupler trigger by safety pin (29), put "R" pin (S) through the hole of safety pin.

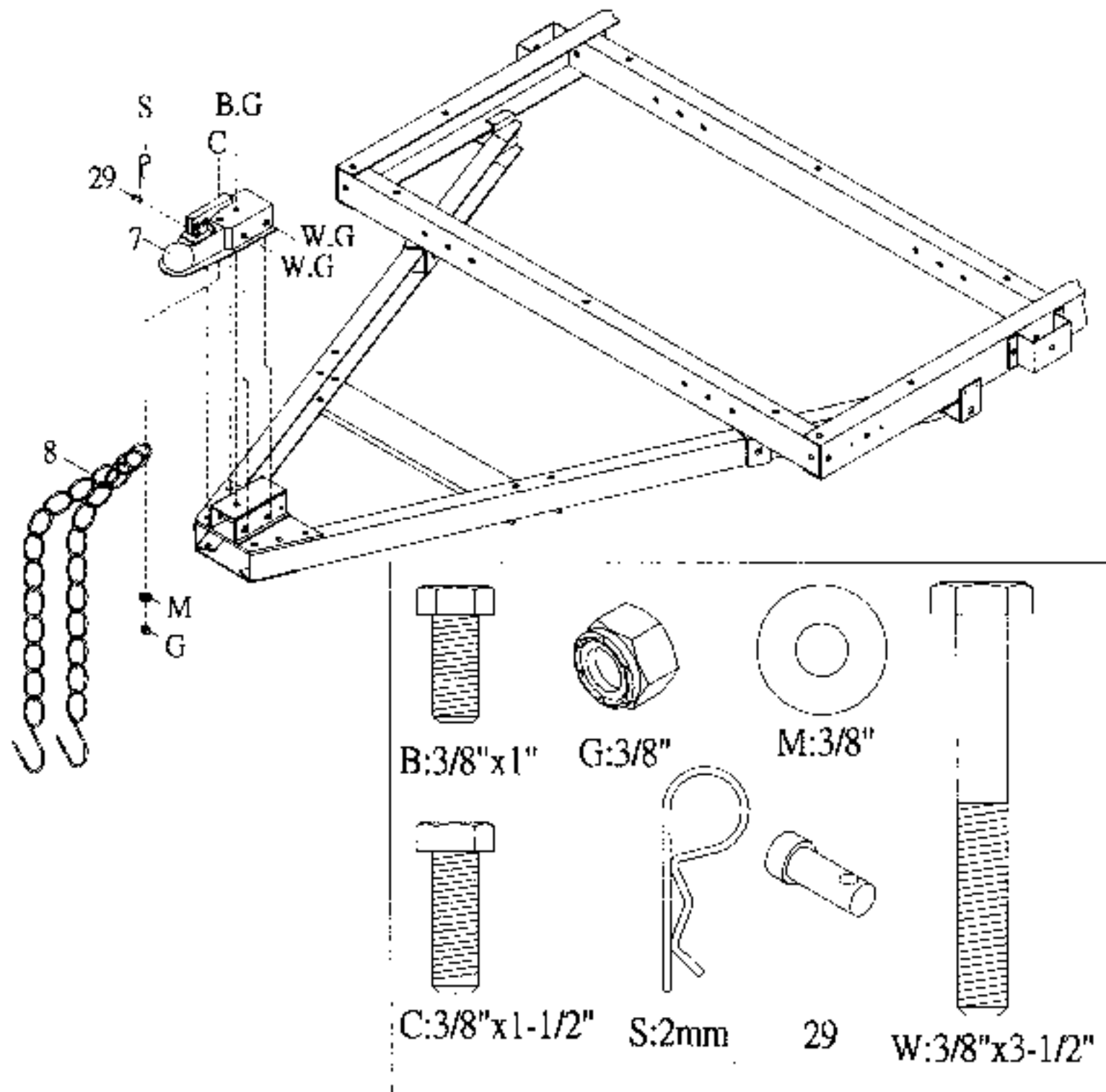

STEP 9

1. Attach stake clamps (25) to front/rear cross member by using $3/8"$ x $3/4"$ bolts (A) and $3/8"$ nylon nuts (G).
2. Tighten rear portion frame to spring hangers (12L, 12R) by using $3/8"$ x 1" carriage bolts (D), $3/8"$ spring washers (L) and $3/8"$ hex nuts (H), as shown in diagram.
3. Open the lens of side running light (24), secure it to side rail by using 4 mm self tapping screw (R), as shown in diagram.

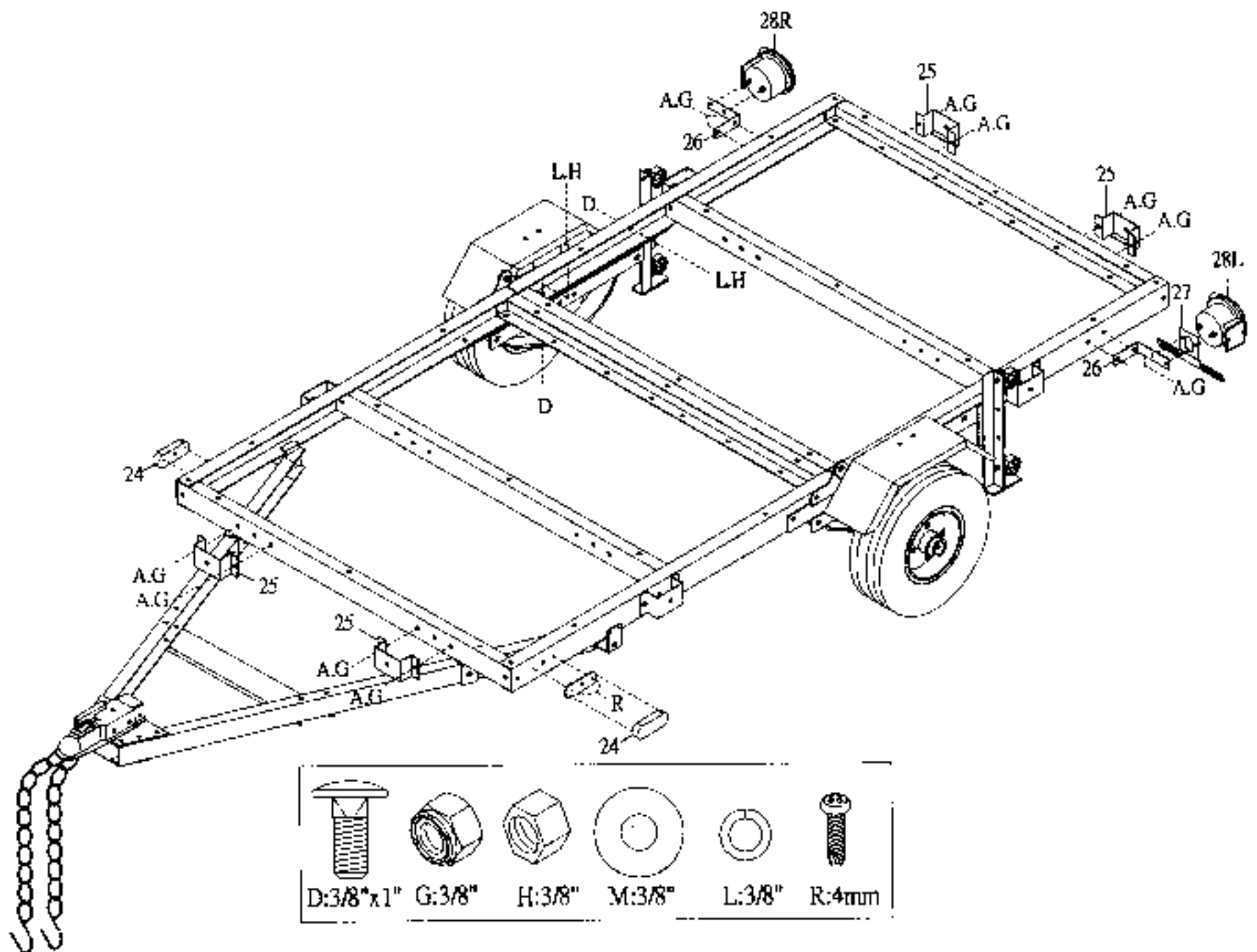

STEP 10

TRAILER LIGHT KIT

WIRING DIAGRAM AND INSTRUCTION

Check alignment of all parts and install the 4-wire vehicle connector in trunk area of your car. Locate the connector plug near the hitch ball and lay out wire. Connect the brown wire to the tail light by stripping, wrapping and taping connector; similarly connect the yellow wire to the left signal & stop light wire, and the green to the right signal & stop light wire. Some foreign vehicles may require an adaptor to convert their 5 wires system to wire vehicle connector.

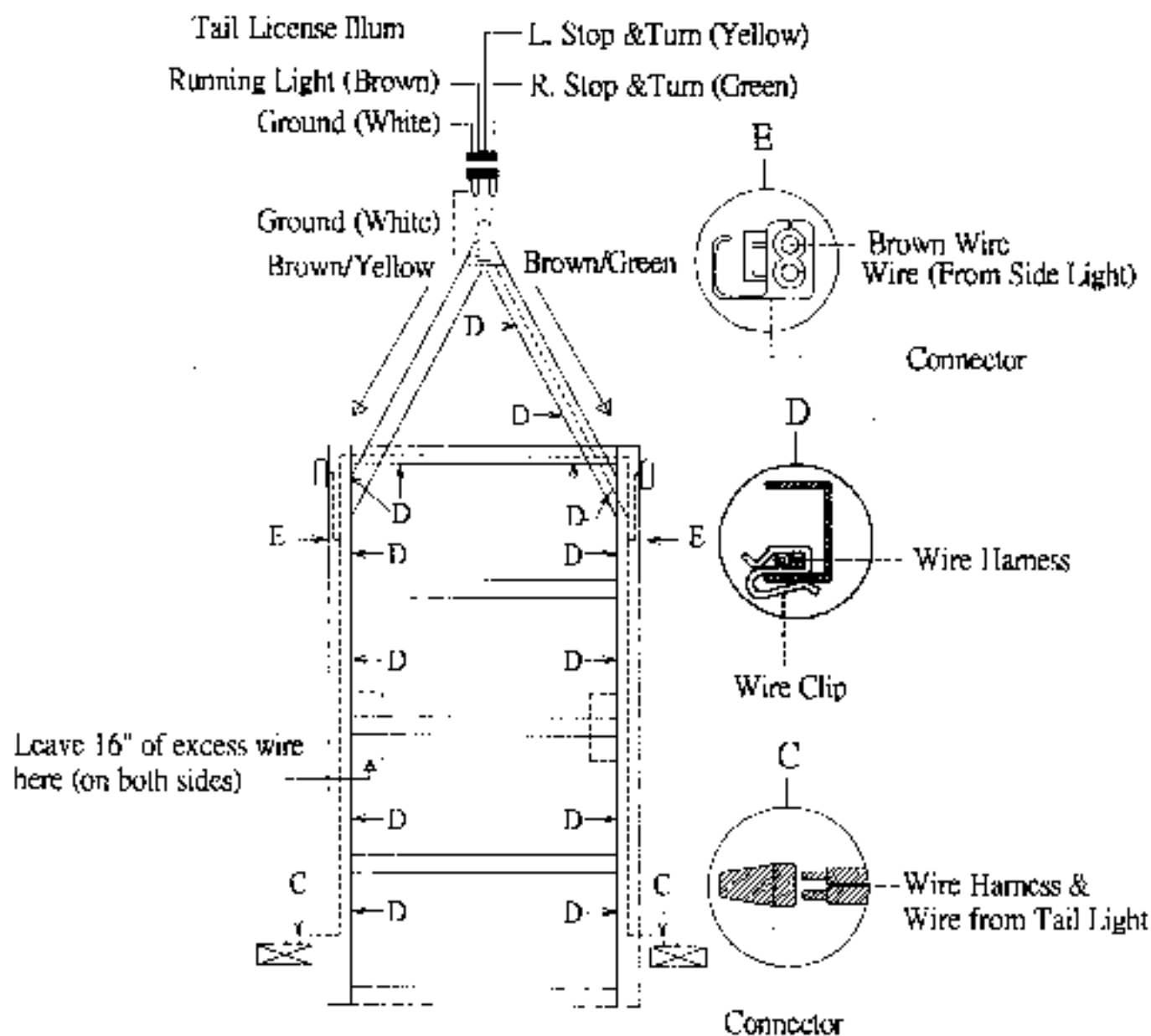

1. Attach white ground wire at plug end of wiring harness to the small hole in towbar with 1/4" self tapping screw.
2. Leave about 18" of wire beyond the coupler and lay out wire on the inside of towbar and side rail as shown. Push on the wire clips.
3. Connect the wire lead from the running light to the brown wire on each side with the wire connector. Use pliers to squeeze the connector closed. Push on wire clips to hold wires down the rail of the trailer.
4. Cut yellow/brown and green/brown wires to appropriate lengths and strip ends of wires 3/4".
5. Make taillight connections as per color code:

LEFT SIDE

Trailer Wire	Tail Light
Yellow	Red wire
Brown	Two black wires

RIGHT SIDE

Trailer Wire	Tail Light
Green	Red wire
Brown	Two black wires

STEP 11

1. Unscrew carriage bolts (a) from side rail of rear section. Fold rear section over front and secure with it on front cross member by using 3/8" x 2" bolt (V) and 3/8" hex nut (H).
2. Tilt trailer onto casters, remove 3mm "R" pin (Q) and L latch (9) from the front cross member then fold the tongue down.
3. NOTE: If there are long time do not fold the rear section, please assemble the rear frame and spring hanger by 3/8" x 1" carriage bolts (D), 3/8" spring washers (L) and 3/8" hex nuts (H).

⚠ WARNING!

- When lifting and lowering the trailer, it needs at least two persons at all time.
- When moving the trailer, it is important to make sure that the ground is flat and solid.
- When storing the trailer, please make sure to place the trailer against the wall, then tie the trailer to the wall to prevent it from falling.
- Keep out of reach of children in case the trailer drops.

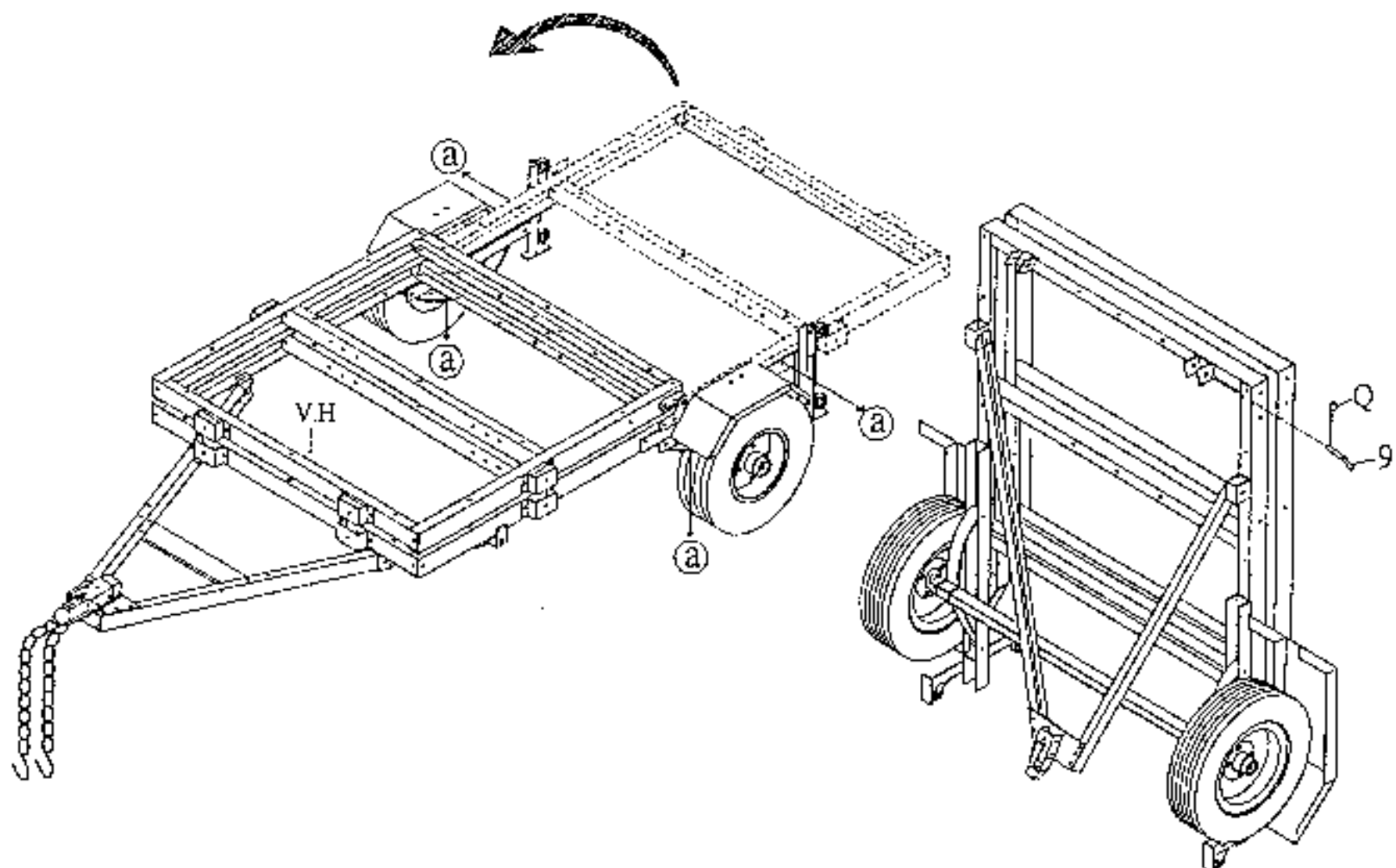

SPECIAL NOTICE FOR COUPLER

Only use a 1-7/8" ball hitch on your towing vehicle. Pull trigger and lift handle. Place coupler over trailer hitch ball and push down on handle until trigger locks in slot.

Pull up and down on the coupler to insure the ball is fitting snugly in the coupler. There should be no play between the ball and coupler. If there is play, tighten the adjustment nut until no play is present. If the nut is too tight, the handle will not lock.

NOTE: To reduce friction the ball hitch and coupler, apply a layer of multipurpose lithium grease over ball hitch. Wipe off excess grease when not in use to avoid staining clothes.

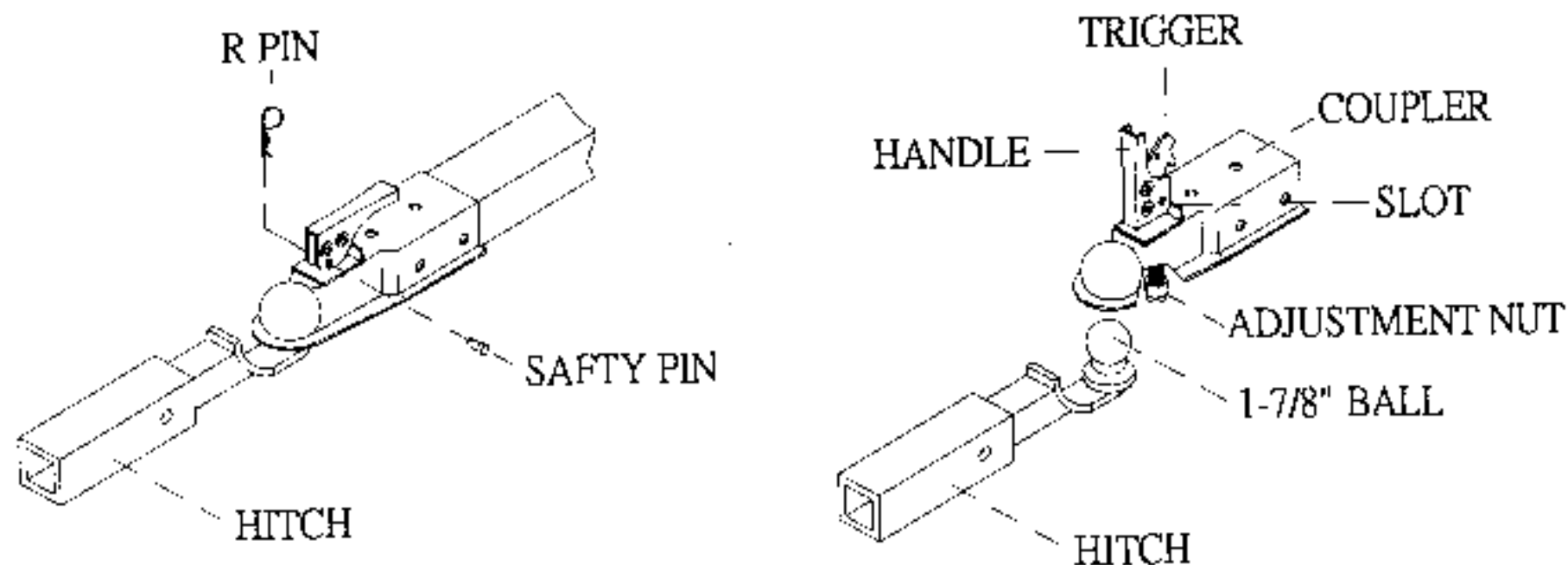

TRAILER LICENSING NOTICE

Some states may consider that this trailer kit is specially constructed or homemade vehicle for registration, licensing and/or titling purposes.

The M.C.O. (Manufacturer's Certificate of Origin) supplied with your trailer should be filed out and signed by the dealer transferring ownership to you.

When licensing your trailer, you will need the signed M.C.O. a purchase invoice, cash register receipt, or bill of sale showing the purchase and retail sales tax or use tax collection by the retailer.

Take these to your local Department of Motor Vehicle and upon payment of the appropriate State fees, you will be issued a title, registration and license plate (if required). Some states will require inspection of the assembled and finished trailer kit before issuing a title/registration/license.

If you require additional information or guidance on licensing or titling, please consult your State Department of Motor Vehicle.

Available Accessories

- Spare tire (Not Included)
- Spare tire holder (Not Included)

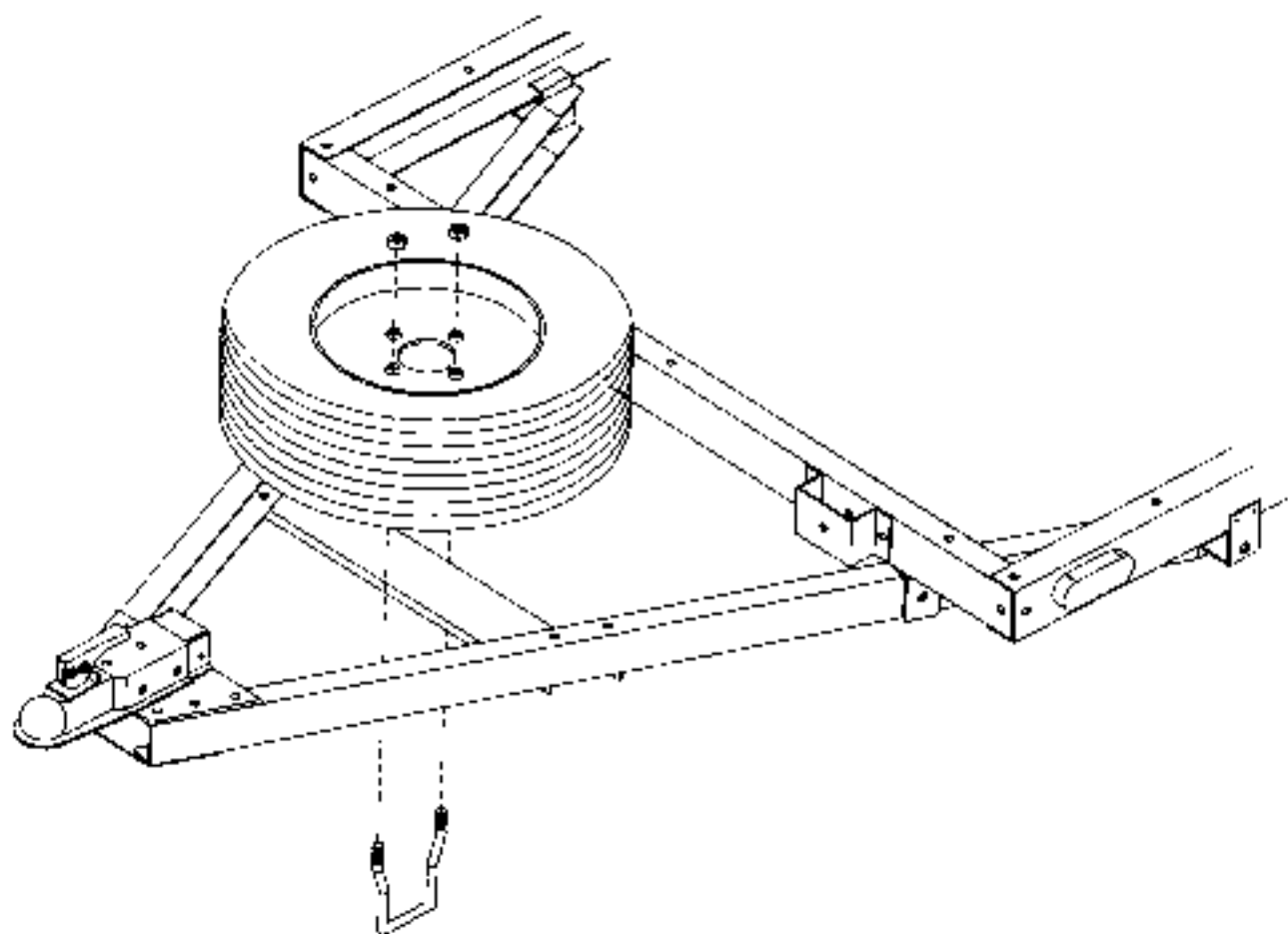

- Trailer stand (Not Included)

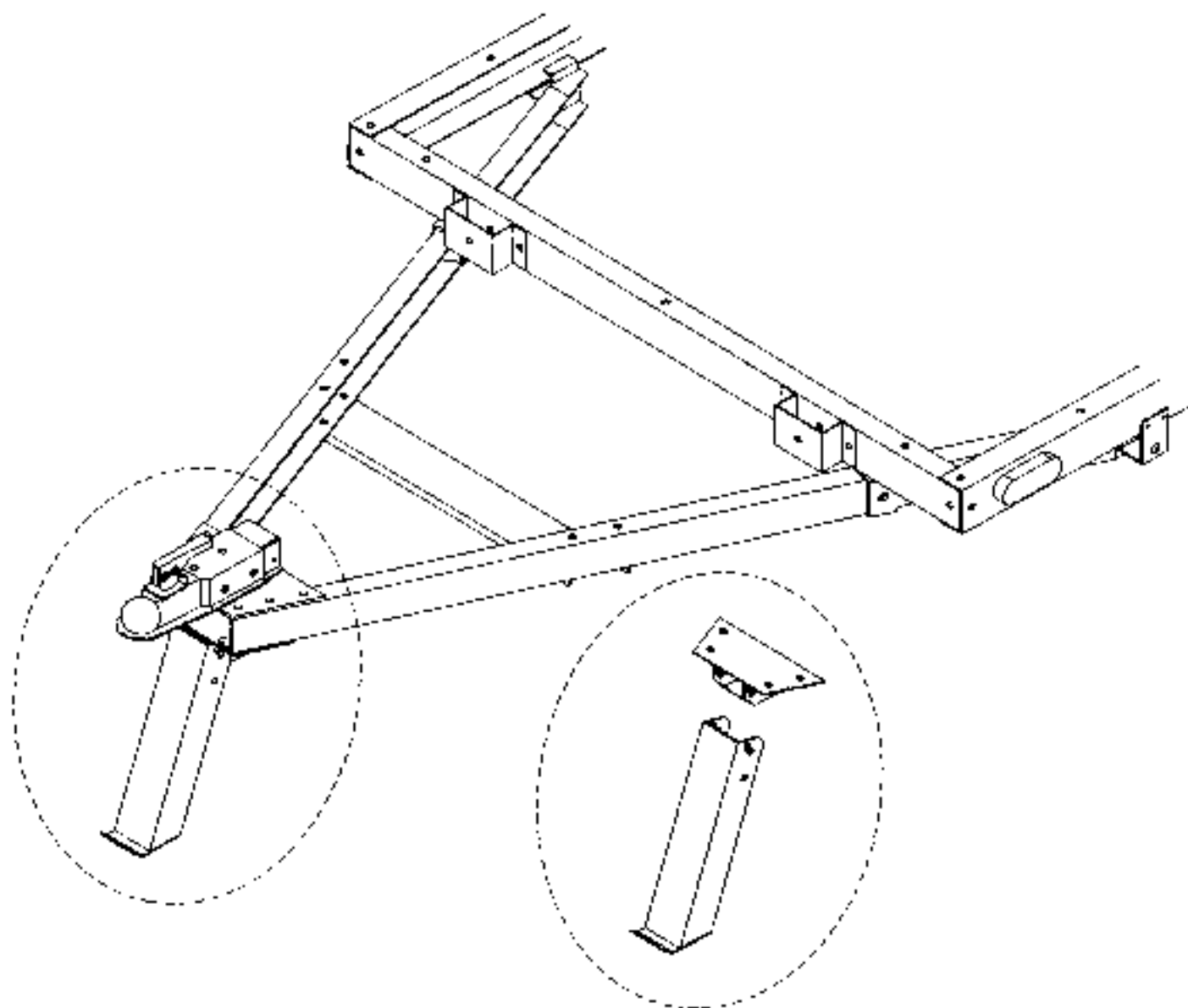

SAFE USE AND OPERATION RULES

1. TOWING VEHICLE:

- Make sure vehicle is capable of towing the load.
- Excess speed is the second highest cause of car-trailer accidents. Recommended maximum speed for all passenger cars towing trailers is 45 M.P.H.

2. HITCH, BALL, COUPLER:

- Check that the hitch on the towing vehicle is capable of towing the trailer. The towing capability of the hitch is normally stamped on hitch drawbar.
- Make sure the coupler and the ball are the same sizes and are rated equal to or greater than the load.
- Never attach anything other than the proper size coupler to the ball for towing.

3. SAFETY CHAIN:

- Be sure to use safety chains.
- Check that safety chains are attached to towing vehicle with the same length for each side.
- Do not allow chains to drag on ground.

4. LOADING:

- Never overload trailer. Maximum load is 970 pounds.
- Load trailer evenly from side to side with 60% of the load forward of the axle. It is important that the tongue be pressing down on the hitch, but not exceeding a downward force of 90 pounds.
- Reduce weight in car trunk and rear seat areas by amount of tongue weight of your trailer.
- It is against the law to carry passengers in the back of any trailer.

5. LIGHTING:

- Check lighting before each use and every 100 miles to be sure stop tail and turn signals are working properly.
- Replace any broken lenses, reflectors or bulbs.
- Check wires for good connections and possible fraying or wearing of insulation.
- Bulbs supplied with this trailer are for 12 volt system.
- Bulbs used in tail light are: Number 1157 (Stop and tail), 1895 (Side).
- Bulb for clearance is: Number 194.

6. TIRES:

- Check tire for wear and proper inflation before each use and every 100 miles.
- Please keep the tire pressure (PSI), as shown on the tire.
- Check and tighten wheel nuts. Torque to 85-90 FT-LBS. Re-torque after first 50 miles.

7. OPERATION:

- Know how to properly control your towing vehicle-trailer combination on the highway under all conditions. Remember the loaded weight of the trailer will increase your braking and stopping distance appreciably.
- When towing a trailer over long distance stop and check tightness of all connections lights and running gear every 100 miles.
- Carry emergency flares, and fire extinguisher if required for operation in your state.
- It is desirable to carry extra bulbs and fuses if you are towing the trailer at night over any great distance.

8. MAINTENANCE:

- Check and maintain the trailer, coupler, ball and hitch before each use and every 200 miles.
- Inspect hitch and ball for damage in every day use.
- Ball or hitch can be damaged in parking, hitting curbs, dragging when crossing ditches or railroad tracks.
- Check safety chains for wear and do not allow safety chains to drag on ground.
- To prevent bearing damage, disassemble and repack wheel bearing with a good grade of wheel bearing grease every 1000 miles or yearly.
- If you don't know how to repack wheel bearing, take your trailer to a garage for advice.
-

IMPORTANT

The purpose of following notices are to give you tips on safe use and operation of your trailer.

1. Please read the instructions carefully and follow them step-by-step for easy assembly, please maintain this instruction in your file.
2. Please double check the assembling step-by-step, be sure each is followed.
3. Be sure to apply for license as required.
4. Before using, please inspect your trailer.

Notice:

- Re-fill grease on bearing after every 1000 miles of use or yearly.
- Keep tire pressure (PSI) as shown on the tire.
- Please insure you comply with the following before using your trailer:
 1. Tighten U-bolts.
 2. Tighten wheel nuts.
 3. Tighten trigger lock on coupler.
 4. Hook up safety chain.
 5. Trailer load should not exceed its 970 lbs capacity and should be properly secured.
 6. Trailer load size should not exceed trailer's bed board size.

Correct way to load your trailer

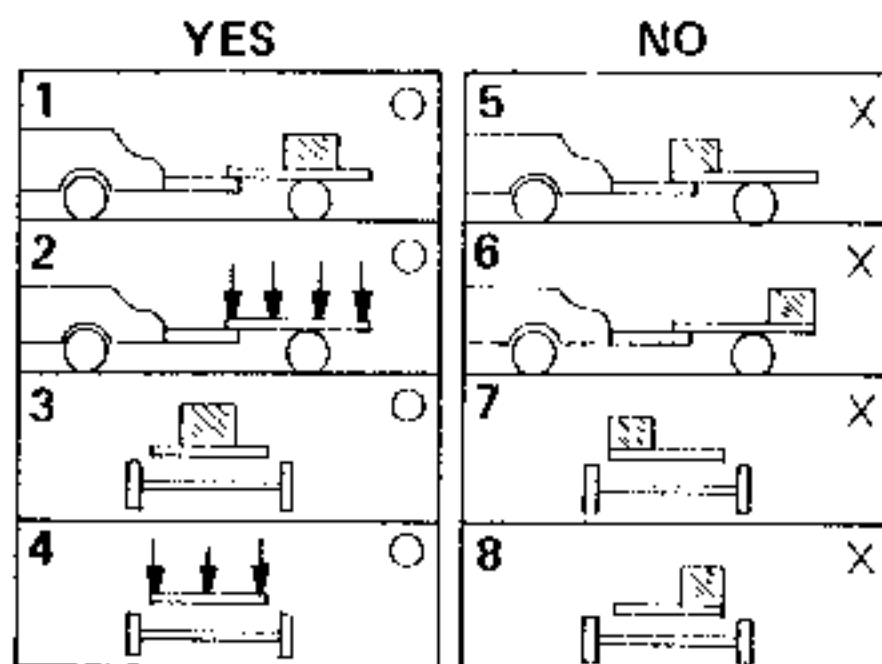

Long Chih Ind. Co., Ltd
P.O. Box 22793, Taipei, Taiwan, R.O.C.

Reporting Safety Defects

If you believe that your vehicle has a defect which could cause a crash or could cause injury or death, you should immediately inform the National Highway Traffic Safety Administration (NHTSA) in addition to notifying Long Chih Ind. Co., Ltd.

If NHTS receives similar complaints, it may open an investigation, and if it finds that a safety defect exists in a group of vehicles, it may order a recall and remedy campaign. However, NHTSA cannot become involved in any individual problems between you, your dealer, or Long Chih Ind. Co., Ltd.

To contact NHTSA you may either call the Auto Safety Hotline toll-free at 1-800-424-9393 (366-0123 in Washington, DC area) or write to:

NHTSA

U.S. DEPARTMENT of TRANSPORTATION

400 7th Street SW. 9NSA-11)

Washington, DC 20590

You can also obtain other information about motor vehicle safety from the hotline.